



- **Fabrication Tips**
- **Recommended Safety Practices**
- **Tools Required**
- **Installation**
- **Procedures**

## Fabrication Tips

A major advantage of using Fibergrate Composite Structures fiberglass products is the ease of fabrication — sawing, grinding, drilling and machining is similar to working with wood, metals and plastics. If possible, perform fabrication “on-site” to increase accuracy. Be sure to allow for saw kerf (usually 3/16”) when performing take-offs and layouts. For a nice looking installation, cut panels so bars of adjoining panels are aligned and leave a solid bar on all sides.

## Recommended Safety Practices

Prior to cutting Fibergrate products, take the following steps:

1. Carefully read the Material Safety Data Sheet (MSDS). If you do not have an MSDS, contact Fibergrate prior to fabricating. Individuals with respiratory ailments should not fabricate FRP products. (*MSDS can be downloaded at [www.fibergrate.com](http://www.fibergrate.com)*)
2. Observe common safety precautions when using cutting tools. Always wear gloves when handling Fibergrate products. Wear approved safety glasses or goggles to protect your eyes and a respirator (mask) to reduce inhalation of dust. We recommend the use of a NIOSH/MSHA approved mask for dust with a permissible exposure limit (PEL) of not less than 0.1 mg/M<sup>3</sup>.
3. Dust from cutting FRP products can cause skin irritation. Wear clothing to reduce dust from coming into contact with skin. If cutting products causes difficulty in breathing or excessive skin irritation, stop immediately and consult a physician.
4. Observe common safety precautions when using the sealing kit. Read and follow instructions enclosed in the kit prior to using. Always wear personal protective equipment when working with FRP products or using a sealing kit. Do not allow resin or catalyst to come in contact with skin.



# Guide to Fabrication



## Tools Required

1. Power saw with a masonry or diamond blade for cement board products (Figure 1); use a circular saw for straight cuts, a jig saw for circular cuts. For large fabrication jobs, use a diamond grit blade.
2. Sawhorses or platform for supporting products while cutting (Figure 2).
3. Tape measure, straight-edge and chalk-line or felt-tip pen for marking cuts.
4. Sealing Kit (Figure 3), to seal edges after cutting. Alternate products to use for sealing Corvex & Vi-Corr gratings are: Devcon 2-Ton Epoxy or 5 Minute Epoxy. For Corvex resins only: Rustoleum Lacquer 1906 Clear, Helmsman Spar Urethane, Krylon-Crystal Clear protective coating.

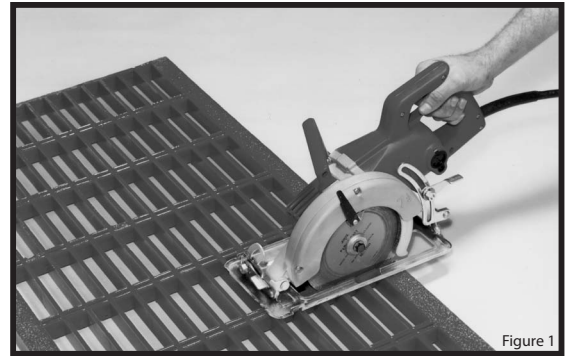

Figure 1



Figure 2

## Installation

1. Provide a minimum of 1-1/2" support around all edges.
2. Use "M-Clip" saddle-type hold-down clips (Figure 4) spaced a maximum of every 48", with a minimum of four clips per panel.



Figure 3

## Procedures

1. Support panel securely so it will not flex or shift during cutting.
2. Mark cuts clearly and carefully. Avoid splitting 1/4" and 5/16" bars. Molded construction allows "stubs" to support weight.
3. Cut from the smooth side (bottom) of a grit-top panel.
4. Use even, steady pressure when cutting. Excessive pressure may cause heat and/or ragged edges. Replace dull blades to prevent heat buildup.
5. Use a sealing kit to coat all cut or sanded surfaces. This is recommended to prevent corrosive chemicals from reaching exposed glass fibers. Carefully read and follow the instructions included with the sealing kit.

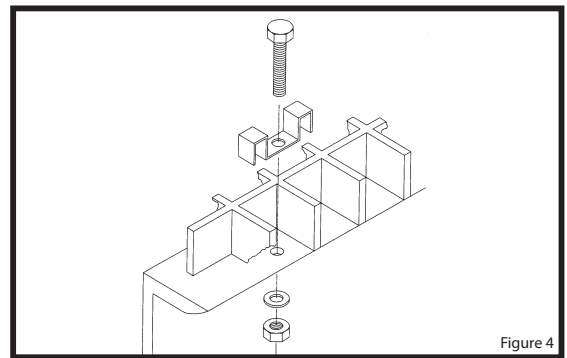

Figure 4



5151 Beltline Rd. Ste 700 Dallas, Texas 75254  
Phone: 972-250-1633 Fax: 972-250-1530



www.fibergrate.com

An **RPM** Company



info@fibergrate.com

Fibergrate Composite Structures Inc. believes the information contained here to be true and accurate. Fibergrate makes no warranty, expressed or implied based on this literature and assumes no responsibility for consequential or incidental damages in the use of these products and systems described, including any warranty of merchantability or fitness. Information contained here is for evaluation only.

